

LOCKSTITCH BUTTON HOLING MACHINE

Computer-controlled, high-speed, lockstitch, buttonholing machine

BH790

-

A

机种别 Model

高速电子平缝锁眼机
Computer-controlled,
high-speed, lockstitch,
buttonholing sewing machine

编号 Code	用途 Application
A	一般钮扣孔车缝 General buttonholing
L	配备120mm长押脚 (适用连续缝功能) 120mm Long presser foot equipped (continuing stitch function applicable)

A 一般钮扣孔车缝
General buttonholing

L 配备120mm长押脚
(适用连续缝功能)
120mm Long presser foot equipped
(continuing stitch function applicable)

BH790 SERIES FEATURES



人体工学的外观设计，机身弧度更大，机臂到机针位置加大，车缝时作业者使用空间更广，确保工作效能

Original setting of counter function, can be added or decreased according to the operator's requirements and needle. The operator has a wider space when sewing to ensure working efficiency.



使用步进及伺服马达驱动，结构大大精简，定位精准，省时省电，维修保养更为方便容易

Driving with stepping and servo motor to simplify the mechanism, to position precisely, to save time and electricity, to maintain easily.



先进的干式机头无油化设计，车缝时不会有油污染车缝物，大大提升车缝品质

Advanced dry-head and oil-free design, no oil stains on the fabric when sewing, effectively raises the sewing quality.

模组化的规格件，更换作业组装方便，多样化功能，提高生产厂商效率

Modularized gauge set, convenient to change and assemble, multi-functional and increases the efficiency for manufacturer.



可选用120mm的大压脚进行门襟钮扣孔连续两次以上车缝，提高生产效率

120mm big presser foot is optionally selected to button-hole shirt-fronting continuously thereby increases productivity efficiency.



多功能人机介面，图像式三色液晶面板，操作容易

Multi-functional and pictographic three-color LCD operation panel, easy to understand and operate.



除错防呆故障预警系统，维修方便容易

Idiotproof and breakdown alert system, convenient to maintain.



内建循环缝系统，可依作业者需求进行多样不同图形或连续性之车缝

Original setting of cycle sewing system, able to sew with many different patterns continuously depending on operator's requirements.



配备断线检知功能，车缝过程中断线立即停止，可退针接缝，不需重新车缝，大大提升车缝效率

Equipped with thread breaking detector. If breaking happens during sewing, the sewing action will stop immediately. After threading again, the needle will return to the same position when breaking happened, no need to restart. Increases sewing efficiency.



内建计数器功能，可依作业者需求递增或递减，方便厂商掌握生产效率

Original setting of counter function, can be added or decreased according to the operator's requirements, favors the manufacturer to control productivity.



内建30个标准图形，可依作业者需求自行变更图形，最多可记忆储存99个图形

Original setting of 30 standard patterns, which can be selected and changed by operator and able to store maximum 99 patterns.



配备小型投射LED照明灯，穿线或调整机针作业方便

Equipped with LED light, convenient for threading or adjusting the needle.

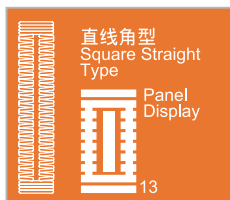

特殊补强车缝设计，让车缝更强固

Special strengthening stitch design makes the sewing much stronger.

BH01



BH790 - A	5	41	34.6	14	30	99	DPX5#14	3600
BH790 - L	5	120	34.6	14	30	99	DPX5#14	3600



锁眼

内建30种标准图形,可依作业者需求自行变更图形,最多可记忆储存99个图形

Button Holing

Original setting of 30 standard patterns , which can be selected and changed by operator able to store maximum 99 patterns.

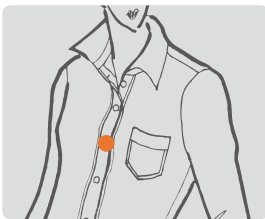

> 选购 OPTION

切刀 TRIMMER			桌板 TABLE
标准配备 STANDARD	选购 OPTION		
9.5	6.4	11.1	BH790 - T1
12.7	14.3	17.5	
15.9	19.1	22.2	
25.4 (mm)	31.8	(mm)	

STANDARD SEWING PATTERN LIST

- 1**
角型
Square Type
- 2**
圆型
Round Type
- 3**
辐射角型
Radial Square Type
- 4**
辐射型
Radial Type
- 5**
辐射直线加固型
Radial Straight Bar-tacking Type
- 6**
半月型
Semilunar Type

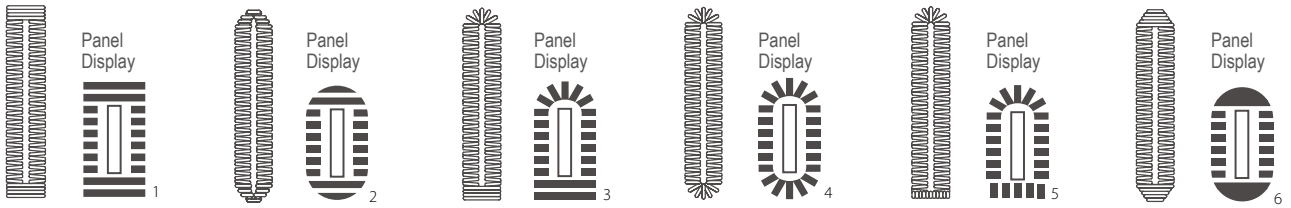

- 7**
圆角型
Round Square Type
- 8**
辐射流动加固型
Radial Taper Bartacking Type
- 9**
圆头扣眼角型
Eyelet Square Type
- 10**
圆头扣眼辐射型
Eyelet Radial Type
- 11**
圆头扣眼直线加固型
Eyelet Straight Bar-tacking Type
- 12**
圆头扣眼流动加固型
Eyelet Taper Bar-tacking Type

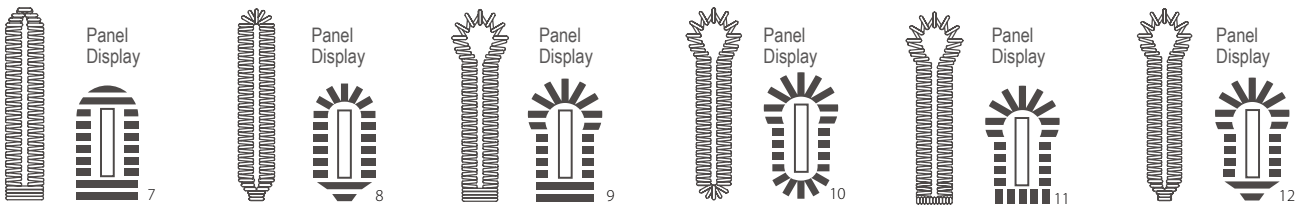

- 13**
直线角型
Square Straight Type
- 14**
半月直线加固型
Semilunar Straight Bar-tacking Type
- 15**
半月流动加固型
Semilunar Taper Bar-tacking Type
- 16**
圆头扣眼半月型
Eyelet Semilunar Type
- 17**
圆头扣眼圆型
Eyelet Round Type
- 18**
角辐射型
Square Radial Type

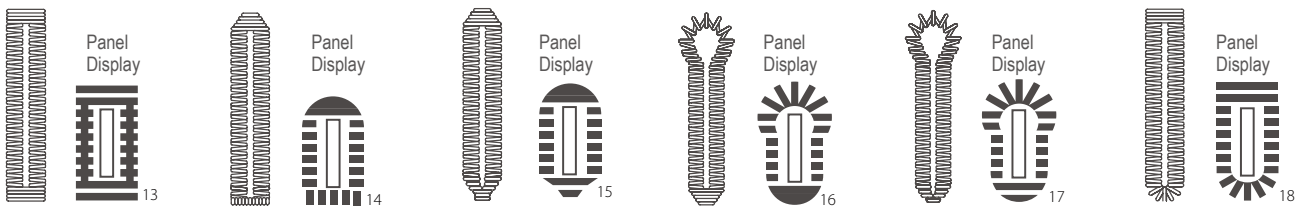

- 19**
角半月型
Square Semilunar Type
- 20**
角圆型
Square Round Type
- 21**
角直线加固型
Square Straight Bar-tacking Type
- 22**
角流动加固型
Square Taper Bar-tacking Type
- 23**
辐射半月型
Radial Semilunar Type
- 24**
辐射圆型
Radial Round Type

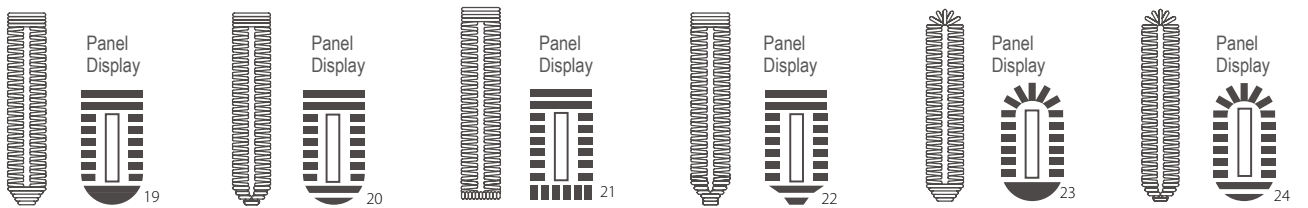

- 25**
半月辐射型
Semilunar Radial Type
- 26**
半月圆型
Semilunar Round Type
- 27**
加固缝
Bar-tacking
- 28**
加固右切断
Bar-tacking, Right Cut
- 29**
加固左切断
Bar-tacking, Left Cut
- 30**
加固中央切断
Bar-tacking, Center Cut

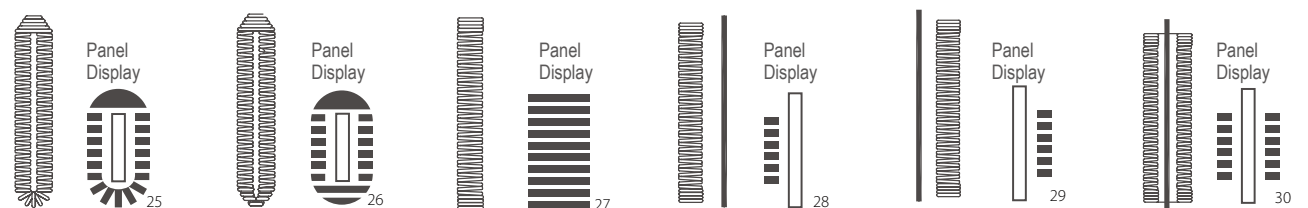

BH790

TRIMMER GAUGE

	A: 零件代号 A: Parts Number	B: 切布刀尺寸(英寸) B: Trimmer Size (inch)	C: 切布刀尺寸(mm) C: Trimmer Size (mm)	备注 Remark
	BL724B	3/8	9.5	标配 Standard
BL724D	1/2	12.7		
BL724F	5/8	15.9		
BL724J	1	25.4	选配 Optional	
BL724A	1/4	6.4		
BL724C	7/16	11.1		
BL724E	9/16	14.3		
BL724G	11/16	17.5		
BL724H	3/4	19.1		
BL724I	7/8	22.2		
BL724K	1-1/4	31.8		

GAUGE SET

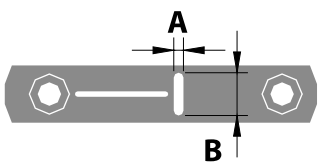
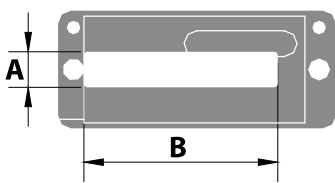
机型 Model	针板 Needle Plate (A x B mm) 	押具 Presser Foot (A x B mm) 	备注 Remark
BH790-A	E201A (1.2 x 6.2)	P570A (4 x 25)	标配 Standard
		P571A (5 x 35)	
		P572A (5 x 41)	选配 Optional
BH790-L		P575A (5 x 120)	标配 Standard